

The **Smith Meter® Guardsman Series Turbine Meter** is a bladed, rotor-type meter which utilizes an upstream, cantilevered stator to support the tungsten carbide, bearing-mounted rotor. It is intended for a wide range of petroleum, petrochemical, and chemical custody transfer measurement applications, such as small product pipelines ranging from Natural Gas Liquids (NGL) to light fuel oils.

Features

- **Stainless steel measuring chamber and internals.**
- **Locking stator** to prevent wear and improve performance.
- **Tungsten carbide bearing system** provides long life on low lubricity liquids.
- **Hydrodynamic thrust balance** to minimize friction and wear on thrust bearings which allows for long service life and high accuracy.
- **125-250 AARH Flange Face Finish.**

Options

- **Bidirectional flow** allows the meter to accurately register flow in either direction.
- **Multiple pickup coils** are used when direction sensing or pulse security is required.
- **NACE compliance** may be necessary when dealing with liquids containing hydrogen sulfide. The meter has housing materials which are certified to be in compliance with the material requirements set forth in NACE Standard MR-01-75 latest revision.
- **Premium ±0.15% and Super Premium Linearity ±0.10%.**
- **AccuLERT ID-2000 Smart Pre-amplifier** for real-time diagnostics of meter performance.

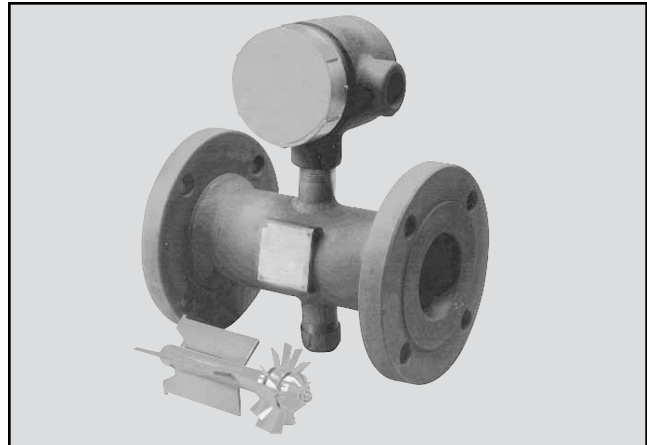

3" Model Code K2BDA

Operating Specifications

Flow Range¹

Meter Size	Units ²	Normal Flow Range ³		Extended Max. Flow Rate ³	Nominal K-Factor (Pulses/Unit) ±5%
		Min. Linear	Max. Linear		
1.5"	USGPM	13	140	190	240
	USBPH	18	200	270	10,080
	L/min	50	530	710	63.4
	m ³ /h	3	32	43	63,400
2"	USGPM	25	280	375	125
	USBPH	36	400	535	5,250
	L/min	95	1,060	1,415	33
	m ³ /h	6	64	85	33,000
3" LF	USGPM	40	420	560	75
	USBPH	55	600	800	3,158
	L/min	150	1,590	2,120	19.8
	m ³ /h	9	96	128	19,800
3"	USGPM	60	650	870	52.7
	USBPH	85	930	1,240	2,215
	L/min	230	2,460	3,280	13.9
	m ³ /h	14	148	198	13,900
4"	USGPM	110	1,200	1,600	25
	USBPH	160	1,700	2,270	1,050
	L/min	415	4,500	6,000	6.6
	m ³ /h	25	270	360	6,600

Linearity

	Normal Flow Range
Standard	±0.25%
Premium	±0.15%
Super Premium (3" and 4" ONLY)	±0.10%

¹ Based on 0.8 sp. gr., 1.5 mPa-s (1.5 cP) liquid.

² Metric units are nominal and may not convert precisely.

³ a. For **bidirectional flow**, the linearity in the reverse direction is ±0.25% and the minimum linear flow rate is 20% of the normal maximum linear.

b. From Normal Minimum to **Extended Maximum**, the linearity is normally not degenerated.

c. Extended Minimum is the flow rate at which the meter can provide a reliable signal, but accuracy (linearity and repeatability) may be diminished.

Repeatability

±0.02% over the entire normal range.

End Connections

Class 150, 300, 600, 900 ANSI B16.5, 125-250 AARH finish raised face (RF) flanges.

PN 16, 25, and 40 DIN 2526 Form C flanges.

PN 63, and 100 DIN 2526 Form E flanges.

Maximum Working Pressure⁴ – PSI (kPa)

ANSI	Carbon Steel Flanges	Stainless Steel Flanges
150	285 (1,965)	275 (1,896)
300	740 (5,102)	720 (4,964)
600	1,480 (10,205)	1,440 (9,929)
900	2,220 (15,307)	2,160 (14,893)

DIN	Carbon Steel Flanges	Stainless Steel Flanges
PN16	232 (1,600)	176 (1,210)
PN25	362 (2,500)	274 (1,890)
PN40	580 (4,000)	439 (3,030)
PN63	928 (6,400)	692 (4,770)
PN100	1,450 (10,000)	1,098 (7,570)

Operating Temperature Range

Meter with	Carbon Steel Flange	Stainless Steel Flange
Pickup Coil	-20°F to 225°F -29°C to 107°C	-40°F to 225°F -40°C to 107°C
Pickup Coil and Preamp	-20°F to 158°F -29°C to 70°C	-40°F to 158°F -40°C to 70°C
Pickup Coil & Preamp with 24" Standoff	-20°F to 225°F -29°C to 107°C	-40°F to 225°F -40°C to 107°C

Consult factory for higher temperatures.

Approvals

UL/CUL, Listed 557 N – Class I Groups C and D; Class I, Zone I, Group IIB; Class I, Zone I, AExd IIB T6 IP66; UNL-UL ENCL. 4, CNL-CSA ENCL. 4; Tamb -50°C to 70°C.

ATEX / IEC Ex

PTB 08 ATEX 1034X, IEC Ex PTB 08.0040X

Ex d IIC T6 Tamb = -40°C to 70°C IP66.

Essential Health and Safety Requirements

EN/IEC 60079-0: Electrical apparatus for potentially explosive atmospheres – General requirements.

EN/IEC 60079-1: Electrical apparatus for potentially explosive atmospheres – Flameproof enclosures 'd'.

EN 60529: 1992. Degrees of protection provided by enclosures (IP code).

EMC Compliance: (by Council Directive 2004/108/EC)

Electromagnetic Emissions: EN 61000-6-3.

Electromagnetic Immunity: EN 55022.

IEC 61000-4-2: Electrostatic Discharge (ESD), Level 3+ (8.0 kV by contact, 12 kV by air).

IEC 61000-4-3: Radiated Electromagnetic Field, Level 3 (10 V/m).

IEC 61000-4-4: Electrical Fast Transient (Burst), Level 2 (1kV).

IEC 61000-4-5: Electrical High Energy Pulses (Surge), Installation Class 3, Criterion B.

⁴ Maximum working pressures are for temperatures of -20°F to 100°F (-28°C to 38°C). Consult factory for maximum working pressures at other temperatures.

Materials of Construction

Body	300 Series Stainless Steel
Flanges	Carbon Steel Optional: 300 Series Stainless Steel
Internals	300 Series Stainless Steel, Except 430 Stainless Steel Blades and Cones
Bearings and Thrust Washers	Tungsten Carbide Journal and Bearings

Installation

The meter must be mounted in a horizontal attitude (±5°) within a suitable flow conditioning assembly. It is recommended that the meter be installed downstream of a strainer for protection and upstream of the flow control valve in the system.

Refer to the installation manual for full instructions.

Applications

High Viscosity

The flow range of turbine meters is reduced considerably when metering viscous liquids.

The minimum flow rate must be increased as the viscosity increases. The following relationships can be used to approximate the increase (reduction in range) that will maintain the stated linearity.

$$\text{Viscous Min. Rate} = \text{Normal Min. Rate} \times \frac{\text{Viscosity (cP)}}{\text{Meter Size (in)}}$$

Note: Caution should be used when dealing with liquids that result in a viscous minimum rate greater than two times the normal, since variations in operating temperature can result in substantial meter factor shifts.

Low Density

When metering light hydrocarbons such as LPG or other liquids with specific gravity less than 0.8, the flow range should be shifted upward. The amount of shift can be approximated by multiplying the normal minimum and maximum flow rates by the following factor:

$$\text{Rate Increasing Factor} = \frac{0.9}{\sqrt{S}}$$

Where: S = The specific gravity of the liquid being metered.

Minimum Back Pressure

In order to prevent cavitation, API M.P.M.S. Chapter 5 recommends a minimum back pressure according to the following:

$$BP = (2 \times \Delta P) + 1.25 V_p$$

Where: BP = Minimum back pressure

ΔP = Pressure drop at maximum flow rate

VP = Absolute vapor pressure at operating temperature

Example:

3" Guardsman at 1,000 BPH - ΔP = 4 psi.

Absolute vapor pressure of butane at operating temperature - Vp = 50 psia.

$$BP = (2 \times 4) + 1.25 (50) = 70.5 \text{ psig}$$

Pickup Coil Specifications

Type: Variable reluctance.

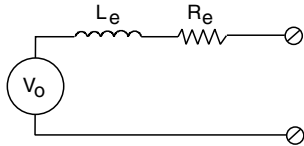

Electrical Characteristics

Effective Series Resistance (R_e): 1,200 Ω ($\pm 10\%$).

Effective Series Inductance (L_e): 400 mH @ 1,000 Hz.

Minimum Open Circuit Voltage (V_o): 300 millivolts p/p at minimum flow rate.

Maximum Transmission Distance: 2,000 ft (610 m) using #20 AWG two-conductor, shielded cable.

Note: A preamplifier is recommended for remote instrumentation that does not have Common Mode Noise Rejection. See Bulletin SS02006 for PA4 Preamplifier Specifications.

Pressure Drop

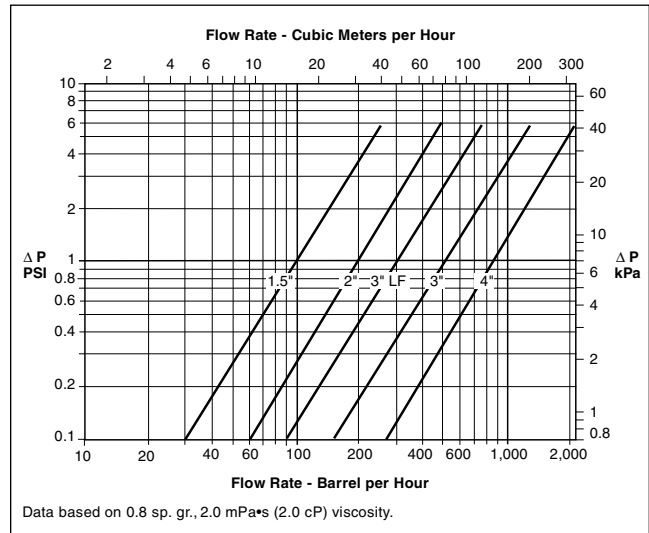

Catalog Code

The following guide defines the correct turbine meter for a given application and the respective catalog code. This code is part of the ordering information and should be included on the purchase order.

1	2	3	4	5	6	7	8	9	10	11
K	2	B	A	A	0	A	0	0	0	0

Position 1: Code

K - Catalog Code

Position 2: Product Line

2 - Turbine Meters

Position 3 and 4: Model

Guardspan G Series - Journal Bearings

- BA - 1.5"
- BB - 2"
- BC - 3" Low Flow
- BD - 3"
- BE - 4"

Positions 5 and 6: Pressure Class and End Connections

ANSI End Connections

- Carbon Steel RF Flg's.
- A0 - Class 150
- B0 - Class 300
- D0 - Class 600
- E0 - Class 900
- 300 Series SS RF Flg's.
- AF - Class 150
- BF - Class 300
- DF - Class 600
- EF - Class 900

DIN End Connections

- Carbon Steel RF Flg's.
- H0 - PN16
- J0 - PN25
- K0 - PN40
- L0 - PN63
- M0 - PN100
- 300 Series SS RF Flg's.
- HF - PN16
- JF - PN25
- KF - PN40
- LF - PN63
- MF - PN100

Position 7: Internal Configuration

- A - Unidirectional Flow, 430 Stainless Steel Blades
- B - Bidirectional Flow, 430 Stainless Steel Blades

Position 8: Pickup Coils and Preamplifiers

Meter Mounted Junction Box(es) with

- 0 - 1 Pickup Coil
- 1 - 1 Pickup Coil and Preamplifier
- 2 - 2 Pickup Coils
- 3 - 2 Pickup Coils and 2 Preamplifiers
- 4 - 2 Pickup Coils and 1 Preamplifier

Pickup Coil(s) with Online Diagnostics with

- S - 1 Pickup Coil and AccuLERT⁶ XU
- T - 2 Pickup Coils and AccuLERT⁶ XU

Extended Temperature Range with Preamplifier

- D - 1 Pickup Coil and 1 Preamplifier on 24-Inch Stand-off
- J - 2 Pickup Coils and 2 Preamplifiers on 24-Inch Stand-off

Extended Temperature with Online Diagnostics with

- E - 1 Pickup Coil and AccuLERT⁶ XU on 24-Inch Standoff
- K - 2 Pickup Coils and AccuLERT⁶ XU on 24-Inch Standoff

Position 9: Testing/Linearity

- 0 - Standard $\pm 0.25\%$ Linearity
- 1 - Premium $\pm 0.15\%$ Linearity
- 2 - Super Premium $\pm 0.10\%$ Linearity⁵

Position 10: Compliance with Electrical and Other Standards

- 0 - UL/CUL Listed
- 3 - ATEX / IEC Ex Certified
- 4 - ATEX / IEC Ex / PED Certified⁷
- 5 - UL/CUL/CRN

Position 11: Specials

- 0 - None
- X - Special - Specify

⁵ Super Premium $\pm 0.10\%$ Linearity is not available for Sizes 1.5", 2" and 3" Low Flow.

⁶ The AccuLERT also provides dual channel preamplification and online diagnostics.

⁷ PED required for all European Countries; equipment must be manufactured by Ellerbek, Germany facility.

Dimensions

Inches (mm) and Pounds (kg)

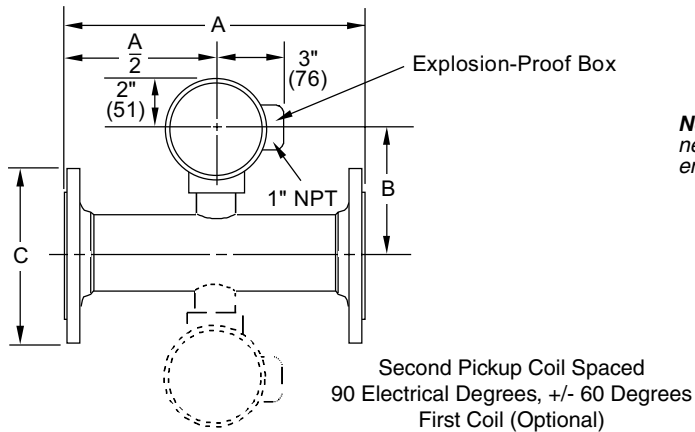

Note: Dimensions - inches to the nearest tenth (millimetres to the nearest whole mm), each independently dimensioned from respective engineering drawings.

Size	A ⁷	B ⁸	Class 150 ANSI		Class 300 ANSI		Class 600 ANSI		Class 900 ANSI		
			C	Weight	C	Weight	C	Weight	A	C	Weight
1.5"	6.0" (152)	6.4" (162)	5.0" (127)	14 (6)	6.1" (155)	19 (9)	6.1" (155)	24 (11)	9.0" (229)	7.0" (178)	40 (18)
2"	6.5" (165)	6.6" (168)	6.0" (152)	20 (9)	6.5" (165)	24 (11)	6.5" (65)	33 (15)	9.0" (229)	8.5" (216)	65 (30)
3" and 3" LF	10.0" (254)	5.1" (130)	7.5" (191)	65 (30)	8.3" (211)	76 (34)	8.3" (211)	45 (20)	10.0" (254)	9.5" (241)	152 (69)
4"	12.0" (305)	5.6" (142)	9.0" (229)	65 (30)	10.0" (254)	80 (36)	10.8" (274)	110 (50)	12.0" (305)	11.5" (292)	160 (72)

Size	PN16		PN25/PN40	
	C	Weight	C	Weight
1.5"	5.9" (150)	13 (6)	5.9" (150)	18 (8)
2"	6.5" (165)	20 (9)	6.5" (165)	20 (9)
3" and 3" LF	7.9" (200)	55 (25)	7.9" (200)	60 (27)
4"	8.6" (220)	60 (27)	9.2" (235)	66 (30)

Related Publications

PA-6 Preamplifier Specification	Bulletin SS02012
Flow Conditioner Specification	Bulletin SS02007
AccuLERT Smart Preamplifier Specification	Bulletin SS02015

avrorarm.ru
+7 (495) 956-62-18