

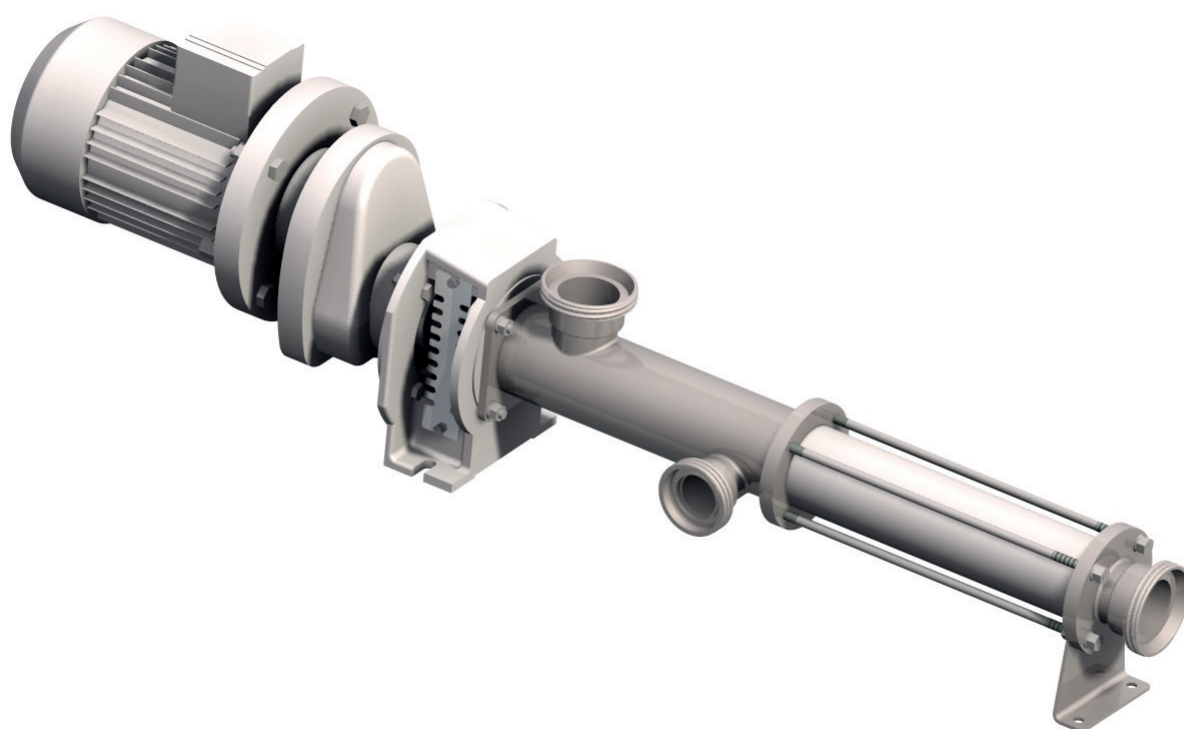

H Range - Hygienic grade



PROGRESSING CAVITY PUMP
Italian Designed & Manufactured

avrorarm.ru
+7 (495) 956-62-18

Legendary Reliability

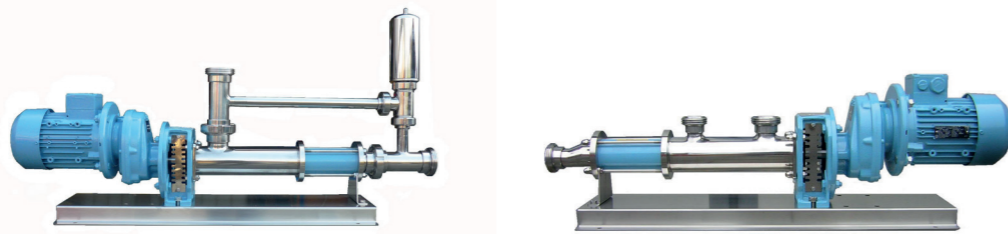

Features:

Hygienic:

We supply hygienic pumps, particularly designed to satisfy the most rigorous requirements and to avoid product contamination and spoiling.

Cleaning:

Manufactured free of any stagnation areas, the "H" range is available with clean in place system (CIP) and bypass ports.

Viscous Products:

For very concentrated viscous liquids, our hygienic models can work at low speeds and can be manufactured with enlarged inlets or with a hopper and an auger to convey the material into the pump.

Shear Sensitive Liquids:

The pumped product is always transferred gently. The progressive cavity pump principle doesn't generate a centrifugal action and there is no big changes in speed which would damage the product inexorably.

Material Selection:

Inside the company we produce the most important components of our pumps, this factor gives us the possibility to keep total control over the quality of the final product.

Discharge Flange:

Polished stainless steel manufactured. Different connections available: DIN 11851, Clamp, RJT, SMS, DIN 2501, ISO, GAS and others

Stator:

Large choice of construction materials: Buna (white and black), EPDM, Viton, Hypalon and others.

Connecting rod:

Stainless steel manufactured and available with feed screw (for high viscosity fluids)

Mechanical seal:

We install a single mechanical seal: Silicon carbide - Viton - Stainless steel. Options: Double mechanical seal with flushing, Quench, etc.

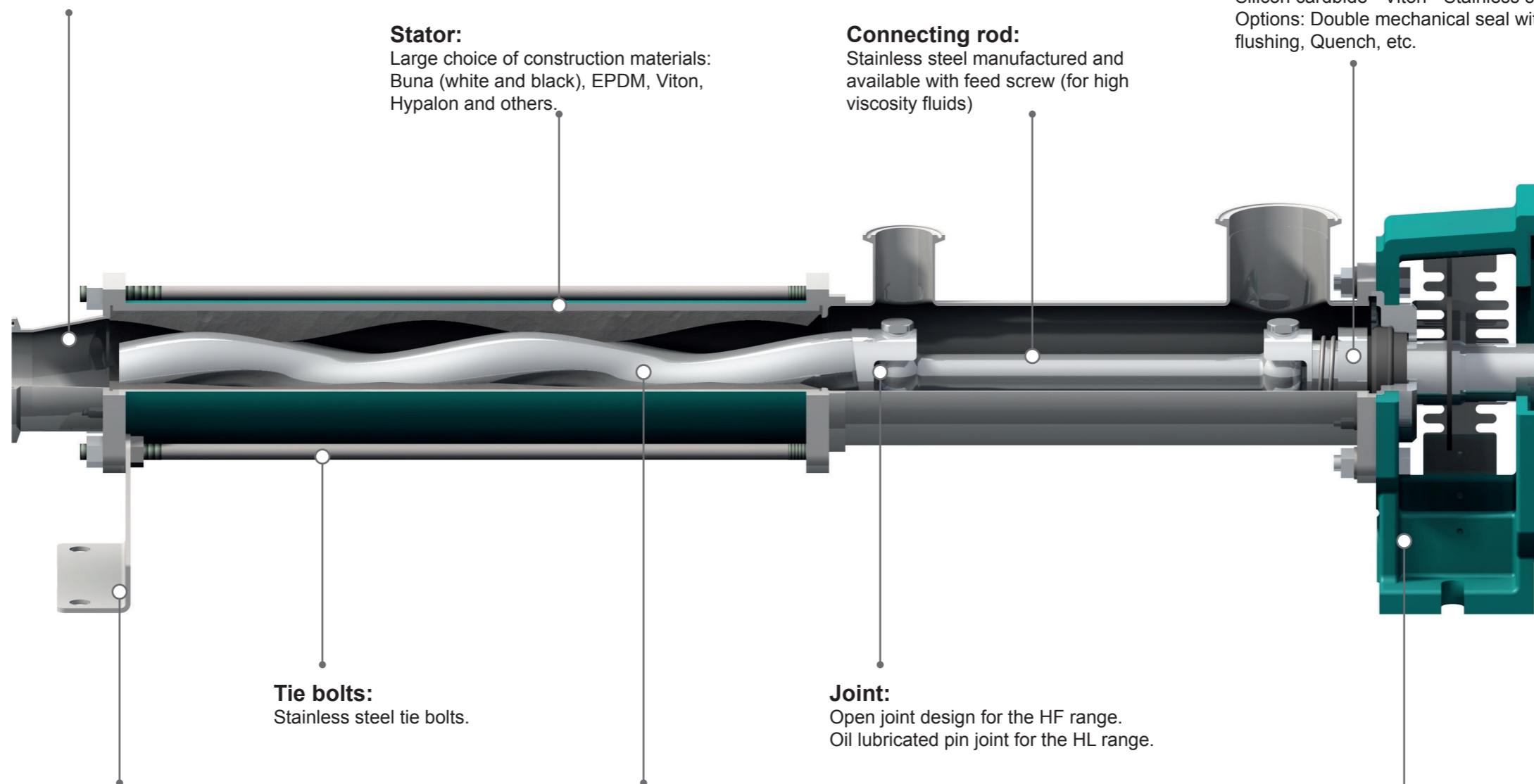

Support:

Stainless steel support foot.

Tie bolts:

Stainless steel tie bolts.

Rotor:

Large choice of construction materials: AISI 304, AISI 316, SAF

Joint:

Open joint design for the HF range. Oil lubricated pin joint for the HL range.

Lantern:

Cast iron design with anticorrosion treatment. Optional: stainless steel design

Markets:



Dairy products



Beverages



Olive oils and fats



Fruit and vegetables



Beer and wine industry



Pharmaceutical and cosmetic industry

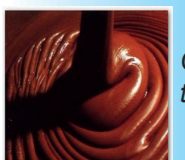

Candy, chocolate and sugar



SYDEX
pump

avrorarm.ru
+7 (495) 956-62-18