

PUMP PERFORMANCE CURVES

TYPE SUBMERSIBLE GENERAL DEWATERING PUMP (HIGH HEAD)	MODEL LH422 -51	FREQUENCY 50 Hz
---	-----------------	-----------------

CUSTOMER'S NAME _____

EQUIPMENT TITLE _____ NO. _____

	STANDARD SPECIFICATIONS	REQUIRED SPECIFICATIONS
DISCHARGE BORE	100 mm	mm
TOTAL HEAD	60/35 m	m
CAPACITY	1.0/2.0 m ³ /min	m ³ /min
MOTOR OUTPUT	22 kW	kW
PHASE x VOLTAGE	3 φ x V	φ x V
CURRENT	A	A
POLES / REVOLUTION	2 P / S. S. 3000 min ⁻¹	P / min ⁻¹
STARTING METHOD	DIRECT ON LINE	
INSULATION CLASS	B	

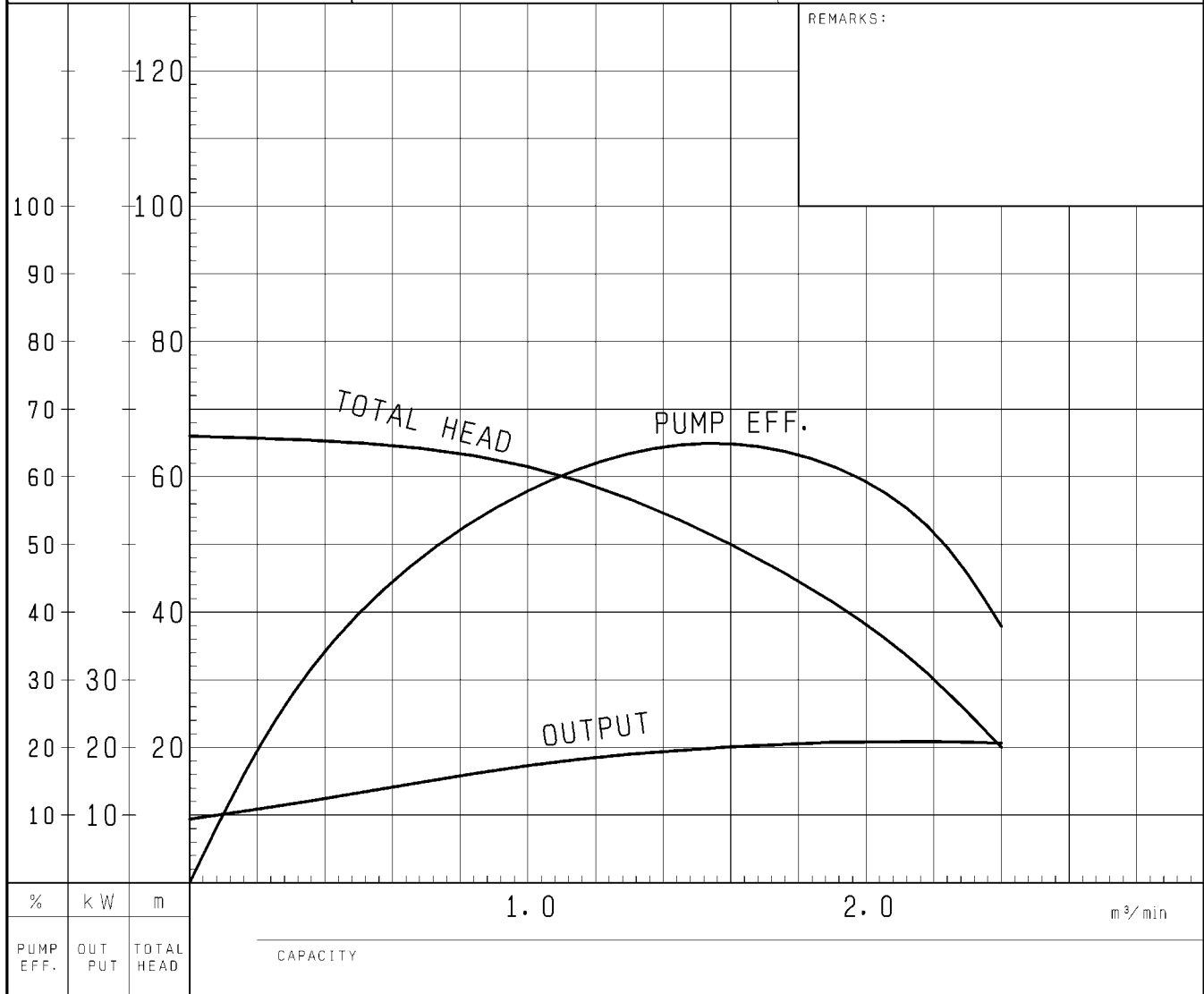

SECTIONAL DRAWING		No.	No.	A-11689-3
TYPE	SUBMERSIBLE GENERAL DEWATERING PUMP (HIGH HEAD)	MODEL	LH619 -51/61 LH622 -51/61 LH422 -51/61	

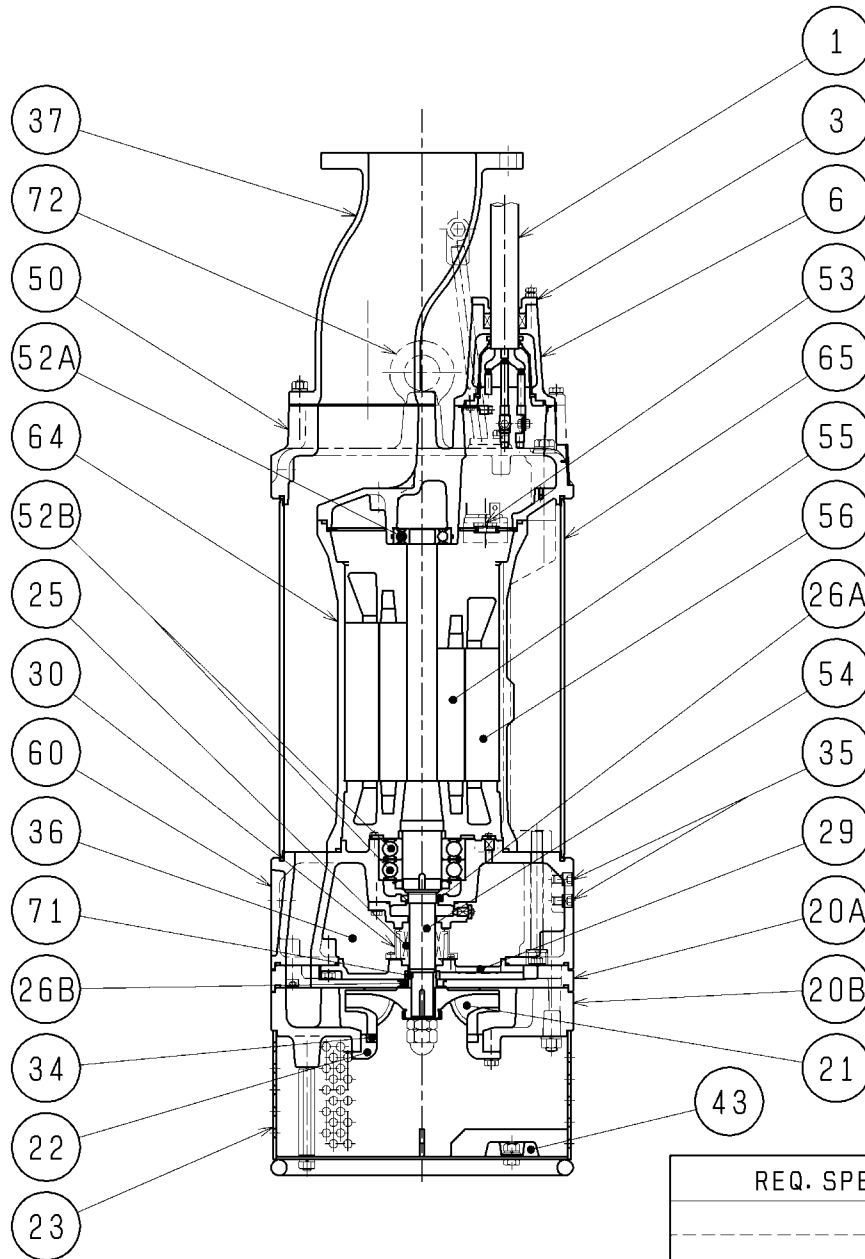

REQ. SPECIFICATION

No.	DESCRIPTION	QTY	MATERIAL / NOTE	No.	DESCRIPTION	QTY	MATERIAL / NOTE
1	Cable	1	Chloroprene Sheath	37	Discharge Pipe	1	Ductile Iron Casting
3	Gland	1	Gray Iron Casting	43	Cathodic Protection Plate	4	Aluminium
6	Stuffing Box	1	Gray Iron Casting	50	Motor Bracket	1	Gray Iron Casting
20A	Casing-upper Half	1	Ductile Iron Casting	52A	Upper Bearing	1	6307ZZC3
20B	Casing-lower Half	1	Ductile Iron Casting	52B	Lower Bearing	1	6311ZZD2C3
21	Impeller	1	Chromium Iron Casting	53	Motor Protector	1	
22	Suction Cover	1	Gray Iron Casting	54	Shaft	1	Stainless Steel 420J2
23	Strainer Stand	1	Structure Steel	55	Rotor	1	
25	Mechanical Seal	1	H-35T	56	Stator	1	
26A	Oil Seal	1	SC40588	60	Bearing Housing	1	Gray Iron Casting
26B	Labyrinth Ring	1	Stainless Steel 304	64	Motor Frame	1	Gray Iron Casting
29	Oil Casing	1	Gray Iron Casting	65	Outer Cover	1	Structure Steel
30	Oil Lifter	1	Plastic	71	Shaft Sleeve	1	Stainless Steel 403
34	Mouth Ring	1	Chromium Iron Casting	72	Eye Bolt	2	Stainless Steel 304
35	Oil Plug	2	Stainless Steel 304				
36	Lubricant		Turbine Oil (ISO VG32)				

DIMENSION DRAWING		No.	No. A-11685-1
TYPE	SUBMERSIBLE GENERAL DEWATERING PUMP (HIGH HEAD)	MODEL	LH422 -51/61 LH430 -51/61

MODEL	Approximate Weight (※)
LH422-51/61	350kg
LH430-51/61	355kg

※excluding cable

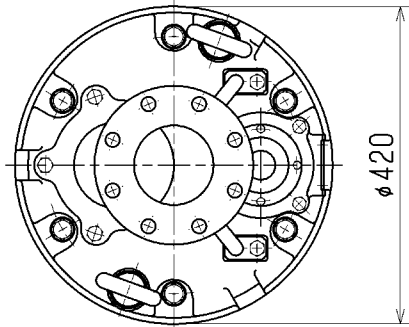

JIS10K Flange
Nominal Dia. ϕ 100

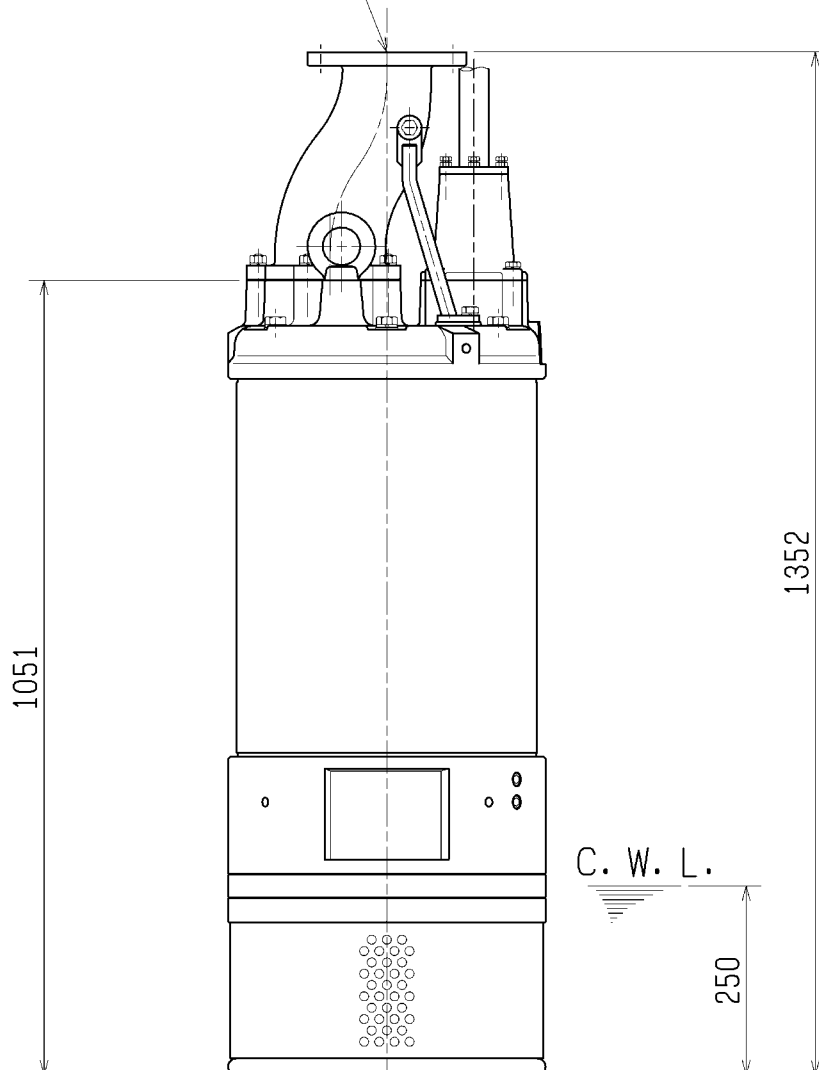

C. W. L. :Continuous Running Water Level