

PUMP PERFORMANCE CURVES

TYPE	SUBMERSIBLE GENERAL DEWATERING PUMP (HIGH HEAD)	MODEL	LH675 -51	FREQUENCY	50 Hz
------	--	-------	-----------	-----------	-------

CUSTOMER'S NAME _____

EQUIPMENT TITLE _____ NO. _____

	STANDARD SPECIFICATIONS	REQUIRED SPECIFICATIONS
DISCHARGE BORE	150 mm	mm
TOTAL HEAD	120 m	m
CAPACITY	1.5 m ³ /min	m ³ /min
MOTOR OUTPUT	75 kW	kW
PHASE x VOLTAGE	3 φ x V	φ x V
CURRENT	A	A
POLES / REVOLUTION	2 P / s. s. 3000 min ⁻¹	P / min ⁻¹
STARTING METHOD	STAR DELTA	
INSULATION CLASS	F	

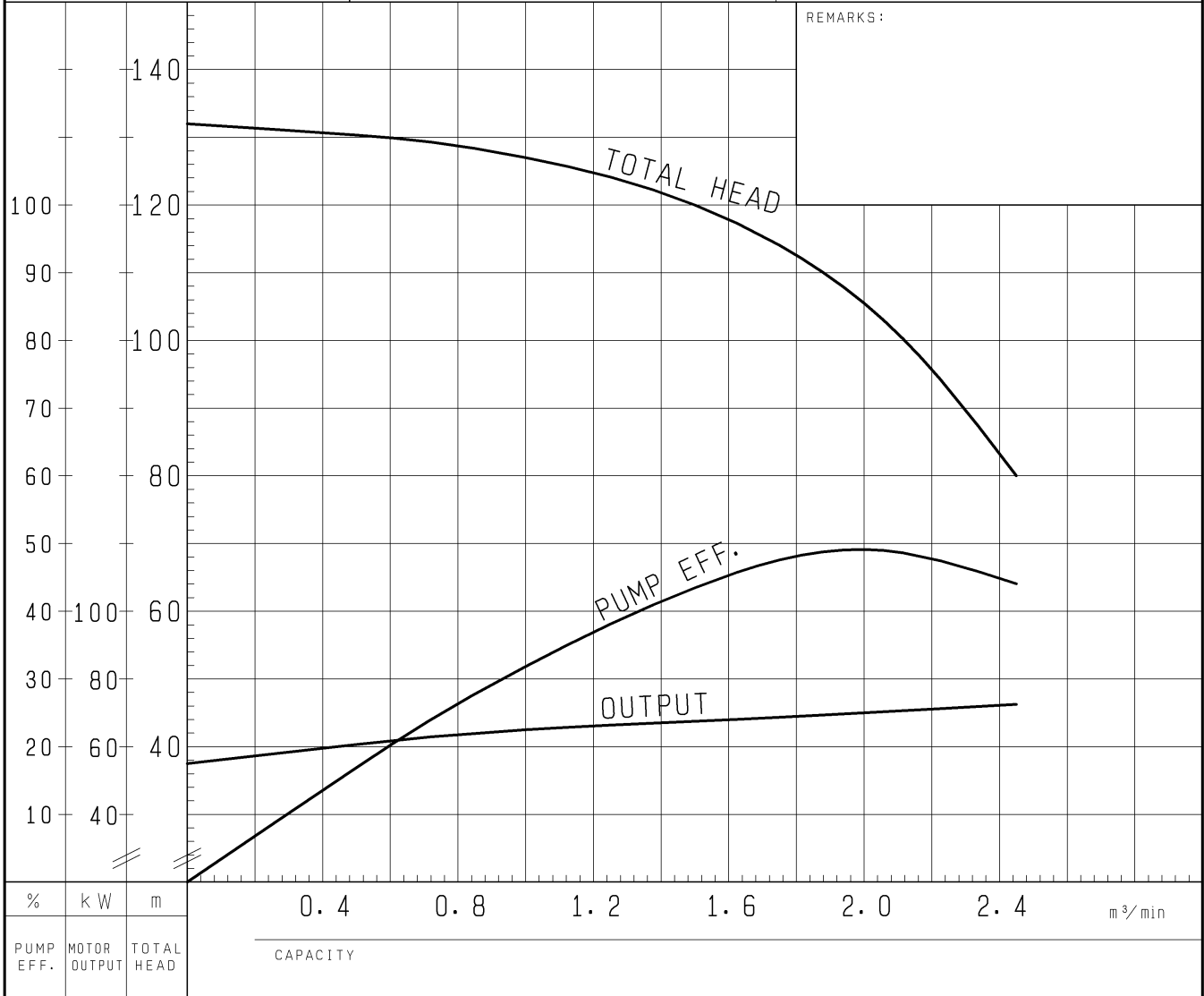

DIMENSION DRAWING		No.	No. A-17765-2
TYPE	SUBMERSIBLE GENERAL DEWATERING PUMP (HIGH HEAD)	MODEL	LH675 -51/61

Approximate Weight (※)
865kg

※excluding cable

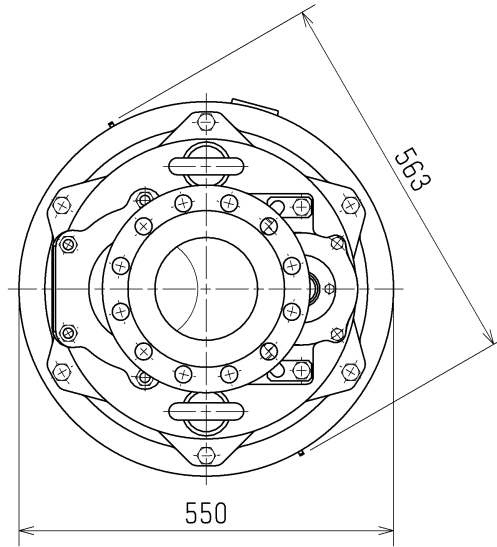

JIS20K Flange
Nominal Dia. $\phi 150$

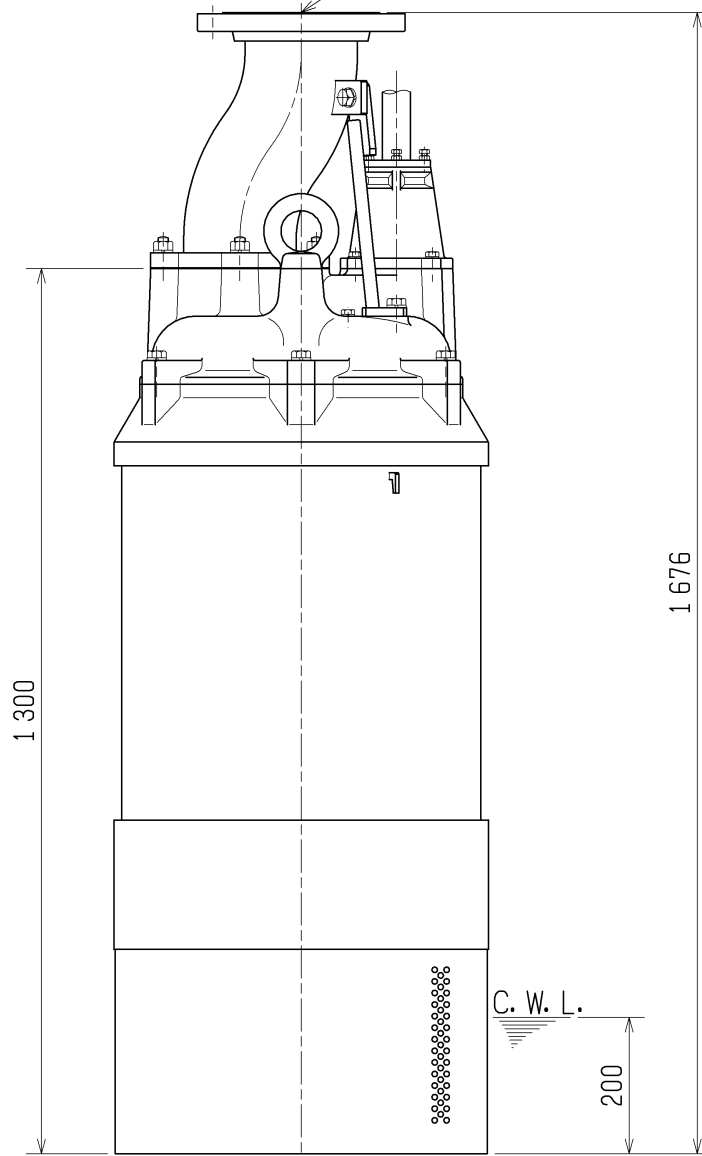

C. W. L. : Continuous Running Water Level

SECTIONAL DRAWING		No.	No. A-17767-1
TYPE	SUBMERSIBLE GENERAL DEWATERING PUMP (HIGH HEAD)	MODEL	LH675 -51/61

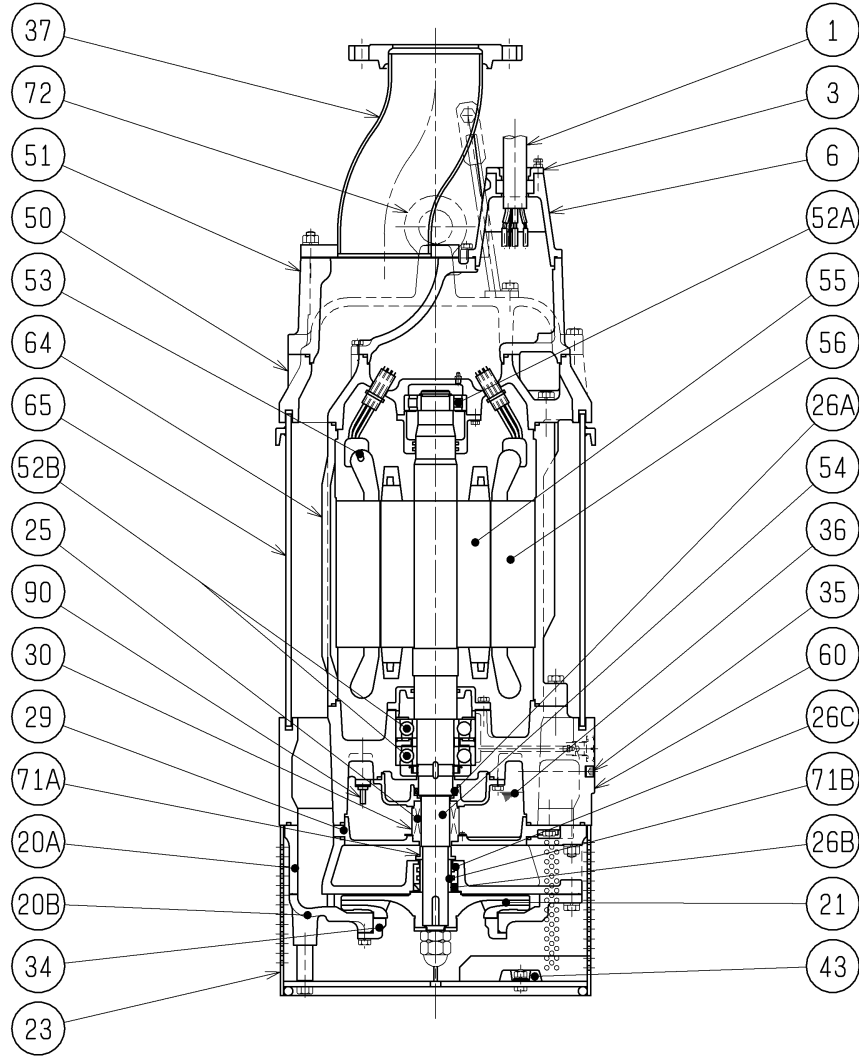

REQ. SPECIFICATION

No.	DESCRIPTION	QTY	MATERIAL / NOTE	No.	DESCRIPTION	QTY	MATERIAL / NOTE
1	Cable	1	Chloroprene Sheath	50	Motor Bracket	1	Gray Iron Casting
3	Gland	1	Gray Iron Casting	51	Head Cover	1	Gray Iron Casting
6	Stuffing Box	1	Gray Iron Casting	52A	Upper Bearing	1	NU310C3
20A	Upper Pump Casing	1	Gray Iron Casting	52B	Lower Bearing	1	7313ATDBC3
20B	Lower Pump Casing	1	Gray Iron Casting	53	Motor Protector	3	
21	Impeller	1	Chromium Iron Casting	54	Shaft	1	Stainless Steel 420J2
23	Strainer Stand	1	Structure Steel	55	Rotor	1	
25	Mechanical Seal	1	H-50T	56	Stator	1	
26A	Oil Seal	1	TC60759	60	Bearing Housing	1	Gray Iron Casting
26B	Oil Seal	1	TCN557812	64	Motor Frame	1	Gray Iron Casting
26C	Labyrinth Ring	1	Stainless Steel 304	65	Outer Cover	1	Structure Steel
29	Oil Casing	1	Gray Iron Casting	71A	Upper Shaft Sleeve	1	Stainless Steel 403
30	Oil Lifter	1	Steel Sheet	71B	Lower Shaft Sleeve	1	Stainless Steel 403
34	Suction Mouth	1	Chromium Iron Casting	72	Eyebolt	2	Structure Steel
35	Oil Plug	2	Stainless Steel 304	90	Leakage Sensor Electrode	1	Stainless Steel
36	Lubricant		Turbine Oil (ISO VG32)				
37	Discharge Pipe	1	Structure Steel and Carbon Steel Pipe				
43	Cathodic Protection Plate	3	Aluminium Alloy				